

ΕΛΟΤ EN 3.07 + Α1

Εθνικός Πρόλογος

Αυτό είναι το Φύλλο Επικύρωσης
του εγκεκριμένου Ευρωπαϊκού
Προτύπου

EN 3-7:2004 + Α1 : 2007

ως Ελληνικού Προτύπου.
Το πρότυπο αυτό διατίθεται στην
Αγγλική, ή Γαλλική ή Γερμανική
γλώσσα από τον Ελληνικό
Οργανισμό Τυποποίησης Α.Ε.

National Foreword

This Endorsement Sheet ratifies
the approval of European
Standard

EN 3-7:2004 + Α1 : 2007

as a Hellenic Standard.
This standard is available in
English, French or German from
the Hellenic Organization for
Standardization S.A.

English Version

Portable fire extinguishers - Part 7: Characteristics, performance requirements and test methods

Extincteurs d'incendie portatifs - Partie 7: Caractéristiques, performances et méthodes d'essai

Tragbare Feuerlöscher - Teil 7: Eigenschaften, Leistungsanforderungen und Prüfungen

This European Standard was approved by CEN on 5 March 2003 and includes Amendment 1 approved by CEN on 30 June 2007

CEN members are bound to comply with the CEN/CENELEC Internal Regulations which stipulate the conditions for giving this European Standard the status of a national standard without any alteration. Up-to-date lists and bibliographical references concerning such national standards may be obtained on application to the CEN Management Centre or to any CEN member.

This European Standard exists in three official versions (English, French, German). A version in any other language made by translation under the responsibility of a CEN member into its own language and notified to the CEN Management Centre has the same status as the official versions.

CEN members are the national standards bodies of Austria, Belgium, Bulgaria, Cyprus, Czech Republic, Denmark, Estonia, Finland, France, Germany, Greece, Hungary, Iceland, Ireland, Italy, Latvia, Lithuania, Luxembourg, Malta, Netherlands, Norway, Poland, Portugal, Romania, Slovakia, Slovenia, Spain, Sweden, Switzerland and United Kingdom.



EUROPEAN COMMITTEE FOR STANDARDIZATION
COMITÉ EUROPÉEN DE NORMALISATION
EUROPAISCHES KOMITEE FÜR NORMUNG

Management Centre: rue de Stassart, 36 B-1050 Brussels

Contents

Foreword.....	4
1 Scope	5
2 Normative references	5
3 Terms and definitions	5
4 General.....	7
4.1 Description of a portable fire extinguisher	7
4.2 Control of discharge.....	8
4.3 Operating position.....	8
4.4 Hose assembly.....	8
4.5 Propellants	8
4.6 Stored pressure extinguishers.....	8
5 Testing of portable fire extinguishers	9
6 Nominal charges, filling tolerances and minimum fire performance.....	9
6.1 Nominal charges	9
6.2 Filling tolerances	9
6.3 A) Design of the filling opening, excluding carbon dioxide fire extinguishers	9
6.4 Minimum fire ratings	9
7 Duration of operation, residual charge and operating temperatures.....	12
7.1 Duration of operation	12
7.2 Residual charge	13
7.3 Commencement of discharge	13
7.4 Effective range of operating temperature	13
8 Retention of propellant	14
8.1 Verification	14
8.2 Acceptance levels.....	14
8.3 Production leak tests	14
9 Dielectric test for water based extinguishers	15
9.1 General.....	15
9.2 Required performance	15
10 Requirements for components.....	15
10.1 General.....	15
10.2 Operation and emission control mechanisms/devices	15
10.3 Safety devices	16
10.4 Filter for water based portable fire extinguishers	16
10.5 Hose and coupling systems	16
10.6 Control valve	16
11 Means of pressure indication	17
11.1 Pressure gauge.....	17
11.2 Pressure indicator	18
12 Horns for carbon dioxide portable fire extinguishers.....	18
13 Portable fire extinguisher mounting bracket.....	19
14 Resistance to corrosion.....	19
14.1 Resistance to external corrosion.....	19
14.2 Resistance to extinguishing medium of extinguishers using water based media.....	19
15 Fire performance.....	20

15.1	General.....	20
15.2	Class A fire rating	20
15.3	Class B fire rating	20
15.4	☐ Class F fire rating	20
16	Portable fire extinguisher identification	20
16.1	Colour	20
16.2	Marking	20
17	Maintenance	24
Annex A	(normative) Duration of operation, residual charge tests	25
Annex B	(normative) Range of operating temperature	26
Annex C	(normative) Dielectric test	27
Annex D	(normative) Operation and emission control mechanisms/devices	29
Annex E	(normative) Test for performance of the hose.....	30
Annex F	(normative) Control valve test	31
Annex G	(normative) Tests on the horn	32
Annex H	(normative) Resistance to corrosion.....	33
Annex I	(normative) Fire tests	34
Annex J	(normative) Measurement of moisture content of wood.....	42
Annex K	(normative) Compaction procedure	43
Annex L	(normative) ☐ Specific requirements for Class F fire extinguisher	45
Annex M	(normative) ☐ Polar solvents	50
Bibliography	52

Foreword

This document (EN 3-7:2004+A1:2007) has been prepared by Technical Committee CEN/TC 70 "Manual means of firefighting equipment", the secretariat of which is held by AFNOR.

This document shall be given the status of a national standard, either by publication of an identical text or by endorsement, at the latest by February 2008 and conflicting national standards shall be withdrawn at the latest by February 2008.

This document includes Amendment 1, approved by CEN on 2007-06-30.

This document supersedes EN 3-7:2004.

The start and finish of text introduced or altered by amendment is indicated in the text by tags **[A1]** **[A1]**.

EN 3 consists of the following parts, under the general title "Portable fire extinguishers":

[A1] *deleted text* **[A1]**

Part 6¹⁾: Provisions for the attestation of conformity of portable fire extinguishers in accordance with EN 3 part 1 to part 5

Part 7: Characteristics, performance requirements and test methods

Part 8: Additional requirements to EN 3-7 for the construction, resistance to pressure and mechanical tests for extinguishers with a maximum allowable pressure equal or lower than 30 bar

Part 9: Additional requirements to EN 3-7 for pressure resistance of CO₂ extinguishers

Part 10²⁾: Provisions valuating the conformity of a portable fire extinguisher to EN 3 part 7

According to the CEN/CENELEC Internal Regulations, the national standards organizations of the following countries are bound to implement this European Standard: Austria, Belgium, Bulgaria, Cyprus, Czech Republic, Denmark, Estonia, Finland, France, Germany, Greece, Hungary, Iceland, Ireland, Italy, Latvia, Lithuania, Luxembourg, Malta, Netherlands, Norway, Poland, Portugal, Romania, Slovakia, Slovenia, Spain, Sweden, Switzerland and United Kingdom.

1) EN 3-6 will be superseded by EN 3-10.

2) EN 3-10 will update and amend EN 3-6. EN 3-10 will supersede EN 3-6.

1 Scope

This standard specifies the characteristics, performance requirements and test methods for portable fire extinguishers.

Reference to the suitability of an extinguisher for use on gaseous fires (class C fires) are at the manufacturer's discretion, but are applied only to powder type extinguishers which have gained a class B or class A and class B rating.

Suitability of extinguishers for use on class D fires (fires involving flammable metals) is outside the scope of this standard in respect of test fires. However, extinguishers claiming class D suitability are covered in all other respects by the requirements in this standard for powder extinguishers.

ⓘ It is considered hazardous for powder and carbon dioxide fire extinguishers to be used on Class F fires. For this reason powder and carbon dioxide fire extinguishers are excluded for conformance with regard to Class F in this European Standard. ⓘ

NOTE The extinction of a metal fire presents a situation so specific (in terms of the metal itself, its form, the configuration of the fire etc.) that it is not possible to define a representative standard fire for the purposes of testing. The efficiency of extinguishers on class D fires needs to be established on a case by case basis.

2 Normative references

This European Standard incorporates by dated or undated reference, provisions from other publications. These normative references are cited at the appropriate places in the text and the publications are listed hereafter. For dated references, subsequent amendments to or revisions of any of these publications apply to this European Standard only when incorporated in it by amendment or revision. For undated references the latest edition of the publication referred to applies (including amendments).

EN 2, *Classification of fires*

ISO 9227, *Corrosion tests in artificial atmospheres — Salt spray tests*

ISO 657-1, *Hot-rolled steel sections — Part 1: Equal-leg angles — Dimensions*

ISO 4470, *Sawn timber — Determination of the average moisture content of a lot*

Farbregister RAL-841-GL.

3 Terms and definitions

For the purposes of this European Standard, the following terms and definitions apply.

3.1

fire extinguisher

appliance containing an extinguishing medium which can be expelled by the action of internal pressure and be directed on to a fire

NOTE This pressure can be stored pressure or pressure produced by the release of an auxiliary gas from a cartridge.

EN 3-7:2004+A1:2007 (E)

3.2

portable fire extinguisher

fire extinguisher which is designed to be carried and operated by hand and which in working order has a mass of not more than 20 kg

NOTE Throughout this standard it is referred to as an "extinguisher"

3.3

clean agent

electrically non-conducting, volatile, or gaseous fire extinguishing medium that does not leave a residue upon evaporation

NOTE Examples are fluorocarbons (FCs), perfluorocarbons (PFCs) and fluoroiodocarbons (FICs).

3.4

halon

agent that contains as primary components one or more organic compounds containing one or more of the elements fluorine, chlorine, bromine, or iodine

3.5

body

shell of the extinguisher not fitted with its accessories but fitted with all its welded/brazed parts

3.6

extinguishing medium

substance contained in the extinguisher which causes extinction of a fire

3.7

charge

mass or volume of the extinguishing medium contained in the extinguisher, expressed as a volume (in litres) for water based extinguishers and as a mass (in kilograms) for other extinguishers

3.8

water based extinguisher

[] extinguisher containing water, water with additive or wet chemical

NOTE This also includes foam []

3.9

powder extinguisher

extinguisher containing fire extinguishing powder

3.10

carbon dioxide extinguisher

extinguisher containing carbon dioxide

3.11

halon extinguisher

extinguisher containing halon

3.12

clean agent extinguisher

extinguisher containing a clean agent

3.13

duration of operation

time during which the extinguishing medium is discharged, without any interruption in the discharge and with the valve fully opened not including discharge of the residual propellant gas

3.14**residual charge**

mass of medium remaining after continuous complete discharge including all propellant gas

3.15**maximum pressure at maximum operating temperature, $P(T_{\max})$ (Pressure experimentally measured)**

pressure measured in the extinguisher after stabilisation during at least 24 h at maximum operating temperature (which is ≥ 60 °C) and for cartridge operated extinguishers, the maximum pressure is the maximum pressure recorded for 0,5 s during a period of three minutes, excluding the first second after release of the propellant gas.

3.16 **T_{\max}**

maximum operating temperature declared by the manufacturer (see 7.4.1)

3.17 **T_{\min}**

minimum operating temperature declared by the manufacturer (see 7.4.1)

4 General**4.1 Description of a portable fire extinguisher**

4.1.1 A portable fire extinguisher is described by the type of extinguishing medium it contains. At present, there are:

water based, including foam (A) and wet chemical (B) extinguishers (see Note 1);

powder type extinguishers;

carbon dioxide type extinguishers;

halon type extinguishers (see Note 2);

clean agent extinguishers.

NOTE 1 Water based extinguishers can be produced with or without a low freeze depressant

Water based extinguishers, including foam, containing different proportions of low freeze depressant shall be treated as separate and distinct models for the purposes of testing the range of operating temperatures (see 7.4.2) and electrical conductivity (see clause 9), and fire rating tests. All other requirements relating to the design and construction of water based extinguishers are applicable to all models irrespective of content.

NOTE 2 Attention is drawn to European Council Regulation 2037/2000 concerning the use of halons

4.1.2 A portable fire extinguisher consists of the following components:

- a) body (see 3.5);
- b) body fittings, which are fixed to or screwed onto the body, and include at least the following:
 - control device(s) (see 4.2, 4.3 and 10.1);
 - hose assembly (see 4.4) and/or horns and/or nozzles;
 - head assembly. This also constitutes the main closure (see 6.3);

EN 3-7:2004+A1:2007 (E)

— operating device (see 4.3).

NOTE The head assembly, operating device and control device(s) can be separate or may be incorporated in a single unit.

c) media (see 4.1.1):

4.2 Control of discharge

Portable fire extinguishers shall be fitted with a self-closing control valve to enable the discharge to be interrupted temporarily (see 10.6).

4.3 Operating position

Extinguishers shall operate without being turned over to an inverted position. The operating device of an extinguisher shall be located on the top of the extinguisher. A control device at the end of the hose shall be permitted. Hand wheel controls of the valve on external propellant cartridges shall be located on the top 60 % of the extinguisher body.

4.4 Hose assembly

Extinguishers having a mass of extinguishing medium greater than 3 kg, or a volume of extinguishing medium greater than 3 l shall be provided with a discharge hose.

The length of the flexible section of the hose assembly shall be 400 mm or greater.

When an extinguisher having a mass of extinguishing medium less than or equal to 3 kg, or a volume of extinguishing medium less than or equal to 3 l is fitted with a discharge hose, the hose assembly shall have a minimum overall length of 250 mm.

4.5 Propellants

Only propellants listed in Table 1 or mixtures thereof, shall be used. The maximum water content shall be as specified in Table 1, except when used in stored pressure water based extinguishers. Tracers may be added to the propellant to facilitate leakage detection, but the tracer need not be indicated in the marking.

Table 1 — Permitted propellants

Propellant	Maximum water content mass fraction, %
Air	0,006
Argon	0,006
Carbon dioxide	0,015
Helium	0,006
Nitrogen	0,006

4.6 Stored pressure extinguishers

Stored pressure extinguishers, except carbon dioxide, shall have a means of checking the presence of pressure, see clause 8 and clause 11.

5 Testing of portable fire extinguishers

Extinguishers for testing shall be stored for at least 24 h at a temperature of (20 ± 5) °C before the tests are carried out and shall be maintained within this temperature range until tested. Tests shall be carried out within 5 min of its removal from storage.

Powder extinguishers shall be subjected to the compaction procedure given in Annex K before the storage period preceding the duration of operation test and the control valve test, and before the fire performance test. Water based extinguishers shall be subjected to the compaction procedure according to Annex K only before the storage period preceding the duration of operation test.

6 Nominal charges, filling tolerances and minimum fire performance

6.1 Nominal charges

Nominal charges of portable fire extinguishers shall be equal to one of the values given in Tables 3 to 8 according to the nature of the extinguishing medium.

6.2 Filling tolerances

The actual charge of the extinguisher shall be equal to the nominal charge within the tolerances given in Table 2.

Table 2 — Filling tolerances

Extinguishing medium	Relative tolerance %
Powder	
1 kg	+ 5
2 kg	+ 3
3 kg	+ 2
All other media	0 - 5

6.3 Design of the filling opening, excluding carbon dioxide fire extinguishers

The filling opening shall have a minimum diameter of

20 mm for extinguishers with a charge of less than or equal to 3 kg or 3 l;

25 mm for extinguishers with a charge of more than 3 kg or 3 l.

The main closure of the filling opening, intended to be removed during service or maintenance, shall be provided with an automatic means of venting any residual pressure from the extinguisher. The initial venting of any residual pressure shall occur when the means of securing the closure, or pressure retaining part, is disengaged by not more than one third of full engagement. 

6.4 Minimum fire ratings

6.4.1 General

Fire classes are defined in EN 2.

EN 3-7:2004+A1:2007 (E)

The minimum fire ratings are specified in **Table 3** to **Table 8** and **L.2**, according to the type of extinguishing medium and the charge.

Fire performance shall be tested in accordance with clause 15, and the extinguisher shall attain a class A rating, a class B rating or both as specified in the relevant table, in accordance with the rating claimed by the manufacturer. Class F extinguishers shall attain a class F rating and may optionally have a class A and/or class B rating.

EXAMPLE A powder extinguisher for which the manufacturer wishes to claim class A and class B ratings achieves, for the size with a 9 kg charge, a minimum fire rating of 27A and 144B.

Clean agent extinguishers shall have a minimum fire rating of 5A and/or 21B for extinguishers with charges in the range 1 kg, 2 kg, 3 kg, 4 kg, 6 kg, 9 kg and 12 kg.

6.4.2 Ratings for class A fires

Fire ratings of extinguishers for class A fires are given in **Table 3** and **Table 4**.

NOTE The numbers in the first column of each table refer to the size of the test fire (see Annex I)

Table 3 — Fire ratings, minimum duration of operation and nominal charges for powder extinguishers

Fire rating	Minimum duration of operation	Nominal permitted charges
	s	kg
5A	6	1
8A	6	1, 2
13A	9	1, 2, 3, 4
21A	9	1, 2, 3, 4, 6
27A	9	1, 2, 3, 4, 6, 9
34A	12	1, 2, 3, 4, 6, 9
43A	15	1, 2, 3, 4, 6, 9, 12
55A	15	1, 2, 3, 4, 6, 9, 12

Table 4 — Fire ratings, minimum duration of operation and nominal charges for water based extinguishers, including foam extinguishers

Fire rating	Minimum duration of operation	Nominal permitted charges
	s	l
5A	6	2, 3
8A	9	2, 3, 6
13A	9	2, 3, 6, 9
21A	9	2, 3, 6, 9
27A	12	2, 3, 6, 9
34A	15	2, 3, 6, 9
43A	15	2, 3, 6, 9
55A	15	2, 3, 6, 9

6.4.3 Ratings for class B fires

Minimum fire ratings of extinguishers for class B fires are given in Tables 5, 6, 7 and 8.

(A) Water based fire extinguishers claiming suitability for use on polar solvent shall additionally pass the tests specified in Annex M and shall be marked accordingly. (A)

NOTE The numbers in the first column of each table refer to the size of the test fire (see Annex I).

Table 5 — Fire ratings, minimum duration of operation and nominal charges for powder extinguishers

Fire rating	Minimum duration of operation	Nominal permitted charges
	s	kg
21B	6	1
34B	6	1, 2
55B	9	1, 2, 3
70B	9	1, 2, 3, 4
89B	9	1, 2, 3, 4
113B	12	1, 2, 3, 4, 6
144B	15	1, 2, 3, 4, 6, 9
183B	15	1, 2, 3, 4, 6, 9, 12
233B	15	1, 2, 3, 4, 6, 9, 12

Table 6 — Fire ratings, minimum duration of operation and nominal charges for water based extinguishers, including foam extinguishers

Fire rating	Minimum duration of operation	Nominal permitted charges
	s	l
34B	6	2
55B	9	2, 3
70B	9	2, 3
89B	9	2, 3
113B	12	2, 3, 6
144B	15	2, 3, 6
183B	15	2, 3, 6, 9
233B	15	2, 3, 6, 9

Table 7 — Fire ratings, minimum duration of operation and nominal charges for CO₂ extinguishers

Fire rating	Minimum duration of operation	Nominal permitted charges
	s	kg
21B	6	2
34B	6	2
55B	9	2, 5
70B	9	2, 5
89B	9	2, 5
113B	12	2, 5
144B	15	2, 5
183B	15	2, 5
233B	15	2, 5

Table 8 — Fire ratings, minimum duration of operation and nominal charges for halon extinguishers

Fire rating	Minimum duration of operation	Nominal permitted charges
	s	kg
21B	6	1
34B	6	1, 2
55B	9	1, 2, 4
70B	9	1, 2, 4, 6
89B	9	1, 2, 4, 6
113B	12	1, 2, 4, 6
144B	15	1, 2, 4, 6
183B	15	1, 2, 4, 6
233B	15	1, 2, 4, 6

7 Duration of operation, residual charge and operating temperatures

7.1 Duration of operation

7.1.1 Minimum duration

The duration of operation shall be greater than or equal to the appropriate value given in [2] Tables 3 to 8 and L.2 [3] when the portable fire extinguisher is tested according to Annex A after being subjected to the compaction procedure in accordance with Annex K (see clause 5).

7.1.2 Spread of measurements

When three extinguishers are tested in accordance with Annex A, after being subjected to the compaction procedure in accordance with Annex K (see clause 5), the duration of operation of each extinguisher shall be within 15 % of the average value.

7.2 Residual charge

The residual charge (see 3.14) of extinguishing medium shall not be more than 10 % of the nominal charge when the extinguisher is tested in accordance with Annex A after being subjected to the compaction procedure in accordance with Annex K (see clause 5).

7.3 Commencement of discharge

When tested in accordance with Annex A, after being subjected to the compaction procedure in accordance with Annex K, all extinguishers shall operate within 4 s of the control valve being opened. When testing extinguishers pressurised by a separate action, the control valve shall be operated within 6 s after activation.

7.4 Effective range of operating temperature

7.4.1 T_{\max} and T_{\min} claimed by the manufacturer shall be used for the tests in 7.4.2 and Annex B.

7.4.2 Extinguishers shall be able to operate between T_{\max} and T_{\min} :

T_{\max} for all extinguishers shall be 60 °C or higher;

T_{\min} excluding water based extinguisher, shall be - 20 °C, - 30 °C or lower;

T_{\min} for water based extinguishers shall be + 5 °C, 0 °C, - 5 °C, - 10 °C, - 15 °C, - 20 °C, - 25 °C, - 30 °C or lower. For water based extinguishers without any protection against freezing T_{\min} shall be + 5 °C.

When tested at T_{\max} and T_{\min} temperature limits, in accordance with Annex B, extinguishers shall conform to the following requirements:

the discharge shall commence within 10 s of the opening of the control valve;

except for CO₂ extinguishers, the duration of operation shall be not more than twice the value established at a temperature of 20 °C. CO₂ extinguishers shall conform to 7.4.3.

the duration of operation shall be not less than 6 s.

the residual charge shall be not more than 15 % of the nominal charge for extinguishers containing BC type powder, and not more than 10 % of the nominal charge for extinguishers containing other media.

7.4.3 The duration of operation of CO₂ extinguishers shall be as follows.

At T_{\max} the duration of operation shall be not more than the value established at a temperature of 20 °C.

At the minimum operating temperature, T_{\min} , the duration of operation shall be not more than 2.5 times the value established at 20 °C.

8 Retention of propellant

8.1 Verification

8.1.1 General

All extinguishers and propellant cartridges shall be designed in such a way as to permit their retention of propellant to be checked at regular intervals.

8.1.2 Weighing

The following shall be capable of being checked by weight:

- propellant cartridges;
- CO₂ extinguishers.

8.1.3 Pressure measuring methods

8.1.3.1 It shall be possible to check the retention of pressure of a stored pressure extinguisher, with the exception of carbon dioxide extinguishers, as specified in 8.1.3.2, 8.1.3.3 or 8.1.3.4.

8.1.3.2 The extinguisher shall be fitted with a connection to enable the internal pressure to be checked directly by an independent apparatus. Such a connection shall be fitted with a pressure retaining cap (see 8.1.3.1) and shall communicate directly to the contents under pressure. Such a pressure retaining cap can be a cap, pressure gauge or pressure indicator.

8.1.3.3 Alternatively, the extinguisher shall be fitted with a pressure gauge conforming to 11.1.

8.1.3.4 Alternatively the extinguisher shall be fitted with a pressure indicator which conforms to 11.2. In addition to this device the extinguisher shall also be fitted with a connection which conforms to 8.1.3.2 in order that the pressure indicator can be checked.

8.2 Acceptance levels

Leakage from an extinguisher, or propellant cartridge, shall not exceed the following:

- a) for stored pressure extinguishers a rate less than or equal to 6 % (v/v) of the expanded gas at 20 °C per year;

NOTE The volume of the expanded gas is the free volume of the gas at 20 °C.

- b) for extinguishers and propellant cartridges tested by weighing, a rate of 5 % of the nominal charge per year;

- c) for extinguishers, pressurised only at the moment of operation, after pressurisation a leak exceeding 5 cm³ of gas per minute, per kilogram or litre of charge of the extinguisher.

8.3 Production leak tests

To test for conformity to 8.2a) and 8.2b), all extinguishers and propellant cartridges shall be tested. A rate of leakage greater than the limit specified in 8.2a) or 8.2b) shall result in the rejection of the extinguisher.

To test for conformity to 8.2c), samples shall be tested to an appropriate sampling plan. A rate of leakage greater than the limit specified in 8.2c) shall result in the rejection of the batch of extinguishers.

9 Dielectric test for water based extinguishers

9.1 General

The dielectric test is designed to establish the suitability of water based extinguishers for use on live electrical equipment by measurement of the electrical conductivity of the discharge stream.

In order to be usable on live electrical equipment, water based extinguishers shall conform to 9.2.

NOTE For the marking requirement see clause 16.

9.2 Required performance

When the extinguisher is in operation and the metallic plate is live, the current between the handle and earth, and between the nozzle and earth, shall be not more than 0,5 mA at any time during the complete discharge of the portable fire extinguisher. The test shall be carried out in accordance with Annex C.

10 Requirements for components

10.1 General

With the exception of the safety device specified in 10.3 no component of the fire extinguisher shall require to be mounted, removed or modified before or during use.

10.2 Operation and emission control mechanisms/devices

The activation of the extinguisher shall not depend upon the repetition of a given action on the same device. For extinguishers other than CO₂ extinguishers, the force or the energy required to activate the operating device(s) shall be no greater than those given in Table 9 for temperatures up to T_{max} .

For CO₂ extinguishers, this force shall be no greater than 200 N at temperatures up to 40 °C and no greater than 300 N at the maximum temperature (T_{max}).

Activation means the totality of actions required for pressurisation (if the extinguisher is not permanently under pressure) and the initial release of the extinguishing agent. If a single device can activate the unit without repetition of movement, it is permissible for the same device to be re-used in order to control the output (see Annex D).

Table 9 — Force or energy required to activate the operating device

Type of device	Maximum force or energy	
	Force N	Energy J
Finger trigger	100	—
Squeeze grip lever	200	—
Screw down hand wheel ^{a b}	100	—
Strike knob	—	2

^a The force shall be measured at the outside edge of the wheel

^b The maximum rotation of wheel to be 360° to achieve fully opening position

10.3 Safety devices

The operating mechanism of the extinguisher shall be provided with a safety device to prevent inadvertent operation. The release of the safety device shall involve an operation distinct from that of the operating mechanism and shall require a force between the limits of 20 N and 100 N.

~~A1~~ deleted text ~~A1~~

The safety device shall be so constructed that any unaided manual attempt, using a force or impact equal to twice the relevant value given in Table 9 to initiate discharge, without first operating this device, does not deform or break any part of the mechanism in such a way as to prevent the subsequent discharge of the extinguisher.

The extinguisher shall be fitted with a safety element. The safety element shall be provided with means to show whether the extinguisher may have been operated. This may be in the form of a wire and seal or a mechanism which prevents re-insertion of the safety element. It shall be possible to see if the safety element has been removed.

10.4 Filter for water based portable fire extinguishers

The discharge from water based portable fire extinguishers shall be through a filter, in order to retain foreign matter. This filter shall be placed upstream of the smallest section of the discharge passage. Each orifice of the filter shall have an area smaller than that of the smallest cross-section of the discharge passage. The total area of the combined filter orifices shall be at least equal to 8 times the smallest cross-section of the discharge passage. This filter shall be accessible to facilitate maintenance operations on the portable fire extinguisher.

10.5 Hose and coupling systems

The hose and coupling system shall function throughout the operating temperature range, and coupling systems shall be designed and fitted in such a way that they cannot damage the hose.

When tested in accordance Annex E, the performance of the hose shall conform to a) or b) as appropriate.

a) For all types except CO₂ portable fire extinguishers:

three times $P(I_{max})$, the test being carried out at $(20 \pm 5) ^\circ\text{C}$;

— twice $P(I_{max})$, the test being carried out at $(I_{max} \pm 2) ^\circ\text{C}$ and at $(I_{min} \pm 2) ^\circ\text{C}$.

b) for CO₂ extinguishers:

— 1.5 times $P(I_{max})$, the test being carried out at $(20 \pm 5) ^\circ\text{C}$;

— 1.25 times $P(I_{max})$, the test being carried out at $(I_{max} \pm 2) ^\circ\text{C}$ and at the minimum claimed temperature.

10.6 Control valve

10.6.1 Extinguishers shall be fitted with a self closing control valve allowing the discharge of the extinguishing media to be discontinued, furthermore, the valve shall be resistant to leakage following the cessation of the emission as specified in 10.6.2, 10.6.3 or 10.6.4, as applicable. Testing shall be carried out in accordance with Annex F.

10.6.2 For extinguishers other than 1 kg and 2 kg powder extinguishers and all CO₂ extinguishers the second value of pressure shall be either, not less than 80 % of the first measured value or not less than 50 % of the pressure measured before opening the control valve.

10.6.3 For 1 kg and 2 kg powder extinguishers the second pressure value shall be not less than 80 % of the first measured value.

10.6.4 For CO₂ extinguishers the second value of the mass shall be not less than 80 % of the first measured value.

11 Means of pressure indication

11.1 Pressure gauge

11.1.1 The pressure gauge shall be capable of being checked to ensure that it is in good working order by an independent apparatus which uses the application of an external pressure for checking the pressure.

11.1.2 The scale of the pressure gauge (see Figure 1) shall have:

- a zero zone (to indicate zero pressure). If there is an end stop for the moving pointer, this shall be on the negative pressure side of the zero zone. The pointer shall not contact the end stop at zero pressure;

- a green zone (working zone), corresponding to the pressures between operating temperatures (see 7.4) with the following tolerances:

-15 % at P_{min} ;

+6 % at P_{max} .

The derived pressures are rounded off to the nearest full or half bar.

The zones either side of the green zone shall be red.

The permitted errors in indication are:

- 1 bar max at the low pressure end of the green zone;

- 6 % at the high pressure end of the green zone;

- the ($P' + 20$ °C) point shall be indicated and the maximum permitted error is $\pm 0,5$ bar.

To ensure that the pressure indication is visible, the pressure gauge shall conform to the following:

- the gauge shall have a moving pointer extending radially into the indicating green zone with a length of between 50 % and 80 % of the green zone height;

- the position of the pointer at both ends of the green zone and at $P' (+ 20$ °C) shall be such that it is clearly visible;

- the gauge shall have a total scale length equal to or greater than 1,5 times the length from zero to the high pressure end of the green zone.

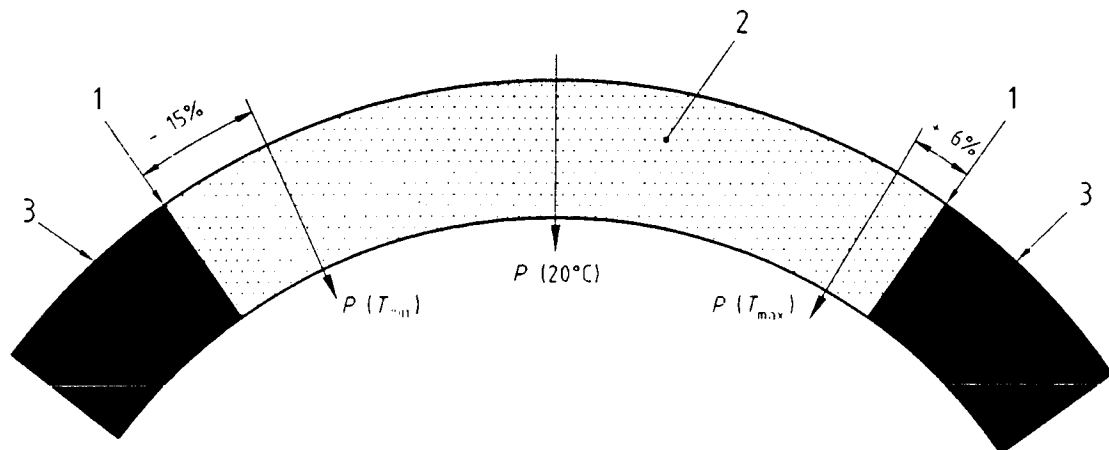

Key

- 1 Rounded to the nearest 0.5 bar
- 2 Green
- 3 Red

Figure 1 — Scale on pressure gauge

11.1.3 When tested at a temperature of $(20 \pm 5) ^\circ\text{C}$, the pressure gauge shall operate within the range of error permitted by 11.1.2 after having been subjected to 1 000 pressure cycles from zero to $P(T_{\text{max}})$ and back to zero at an average rate of pressure change of (20 ± 5) bar/min.

11.1.4 The materials of construction of the pressure gauge which may be in contact with the extinguishing medium and propellant gas shall be compatible with these or protected from them.

11.1.5 All tests shall be carried out at $(20 \pm 5) ^\circ\text{C}$.

11.2 Pressure indicator

11.2.1 The pressure indicator shall indicate whether the extinguisher is in an operable condition.

11.2.2 The change in indication between an operable and an inoperable condition shall occur at a pressure corresponding to the pressure at the minimum operating temperature. The error in this indication shall not exceed 1 bar.

12 Horns for carbon dioxide portable fire extinguishers

12.1 If the horn is not incorporated in the extinguisher (e.g. when it is connected by a hose) it shall be fitted with a handle to protect the hand of the operator against cooling during use.

12.2 After being subjected to the test described in G.1, the horn shall show no damage, and no deformation which alters the diameter of the end of the horn by more than 10 %.

12.3 All connections between the valve and the horn and nozzle shall be such as to prevent loosening or detachment. Where this is provided by mechanical means such as lock-nuts, lock-washers, or spring washers, the torque required to loosen the assembly shall be equal to or greater than 20 N·m. When adhesives, or other methods of assembly, are used the torque required to loosen the assembly shall be equal to or greater than 10 N·m.

12.4 After being subjected to the test described in G.2 the horn shall show no damage, and no deformation which alters the diameter of the end of the horn by more than 10 %.

13 Portable fire extinguisher mounting bracket

The test is carried out on one specimen.

If a mounting bracket is provided with the extinguisher it shall conform to the following requirements:

- removal of the extinguisher from the bracket shall be easy and its method of removal shall be obvious;
- the bracket, when mounted on a wall in accordance with the manufacturer's instructions shall be capable of supporting without permanent deformation a load of at least twice the total mass of the portable fire extinguisher.

NOTE Special brackets to be used for extinguishers in vehicles, on vessels and on aircraft can be subject to national or international regulations.

14 Resistance to corrosion

14.1 Resistance to external corrosion

After having been subjected to the test procedure described in H.1 the two extinguishers both shall conform to the following requirements:

the force, or energy, as applicable, required to activate the extinguisher shall be as specified in 10.2;

the force required to release the safety device shall be as specified in 10.3;

when the extinguisher is tested in accordance with Annex A the duration of operation at $(20 \pm 10) ^\circ\text{C}$ shall be within $\pm 25\%$ of the average value given in 7.1.2;

after operation the pressure gauge, or pressure indicator, if one is fitted, shall return to the indication of no pressure;

when tested in accordance with Annex E, the performance of the hose shall be as specified in 10.5. The test being carried out at $(20 \pm 5) ^\circ\text{C}$;

there shall be no corrosion of the metal of the extinguisher likely to impair its operation or safety.

14.2 Resistance to extinguishing medium of extinguishers using water based media

After having been subjected to the test procedure described in H.2 the two extinguishers both shall conform to the following requirements.

There shall be no visible signs of corrosion of the metal, nor detachment, cracking or bubbling of any protective coating of the body. There shall be no visible change in the colour of the extinguishing medium other than that resulting from the thermal cycling.

NOTE Allowance should be made for the change of colour that occurs naturally due to the temperature changes. It is recommended that two samples of the extinguishing medium are stored in closed glass containers for reference purposes whereby one of the samples is exposed to the same temperature cycling as the extinguisher and compared to the medium in the extinguisher after the test.

15 Fire performance

15.1 General

15.1.1 Fire performance shall be tested in accordance with Annex I (A), Annex L and Annex M (A). Before testing, powder extinguishers shall be subjected to the compaction procedure described in Annex K.

15.1.2 A portable fire extinguisher shall be deemed to satisfy the relevant fire performance requirements when two test fires of a series of three are extinguished. A test series is complete after three fires, or when the first two fires have both been extinguished or have both not been extinguished. Each test series shall be completed before the next is commenced. There is no restriction on the number of series that may be carried out on the same type of portable fire extinguisher without modifications, but a series shall consist of consecutive fires and results shall not be ignored.

15.1.3 If only one test fire from a series of 3 is extinguished, this successful result may be used once only as the initial result in the next set of fire tests on this extinguisher model at a lower fire test rating.

15.2 Class A fire rating

The class A fire rating shall be determined in accordance with I.2.

15.3 Class B fire rating

The class B fire rating shall be determined in accordance with I.3 (b) and suitability for polar solvents, if applicable, in accordance with Annex M (A).

15.4 (A) Class F fire rating

The Class F fire rating shall be determined in accordance with L.5. (A)

16 Portable fire extinguisher identification

16.1 Colour

The colour of the body shall be red RAL 3000 as specified in Farbregister RAL 841 GL

National regulations may require a zone of colour with an area of up to 10 % of the surface area of the extinguisher body to be used to identify the extinguishing agent.

16.2 Marking

The marking on the extinguisher shall be in contrasting colour(s) to the background. The marking shall be divided into five parts as shown in Figure 2.

The marking required for Parts 1, 2, 3 and 5 shall be contained on the same label or in the same frame. The label (or frame) shall be in such a position that it can be clearly read when the extinguisher is on its mounting bracket.

The marking required for Part 4 may be placed elsewhere on the extinguisher

The value of h , for calculating the height of the lettering (which shall be determined by reference to an upper case letter E), except when the marking is in more than one language, shall be not less than:

- 3 mm for extinguishers having a charge \leq 3 kg or 3 l;
- 5 mm for extinguishers having a charge $>$ 3 kg or 3 l.

If the marking is in more than one language, the minimum value of h shall be 2 mm.

The height of the lettering in Parts 1, 2, 3 and 4 shall be as follows subject to a tolerance of $\pm 10\%$.

- Part 1: $1,5 \cdot h$ for the words 'fire extinguisher';
- $0,75 \cdot h$ for the other information;
- Part 2: $1 \cdot h$;
- Part 3: $1 \cdot h$;
- Part 4: $0,5 \cdot h$.

The height of the frame containing Part 5 shall not exceed $1/3$ of the total height of Parts 1, 2 and 3.

NOTE The circled numbers indicate the parts of the marking and the numbers to the right of each part indicate the height of the lettering as a proportion of h (see 16.2)

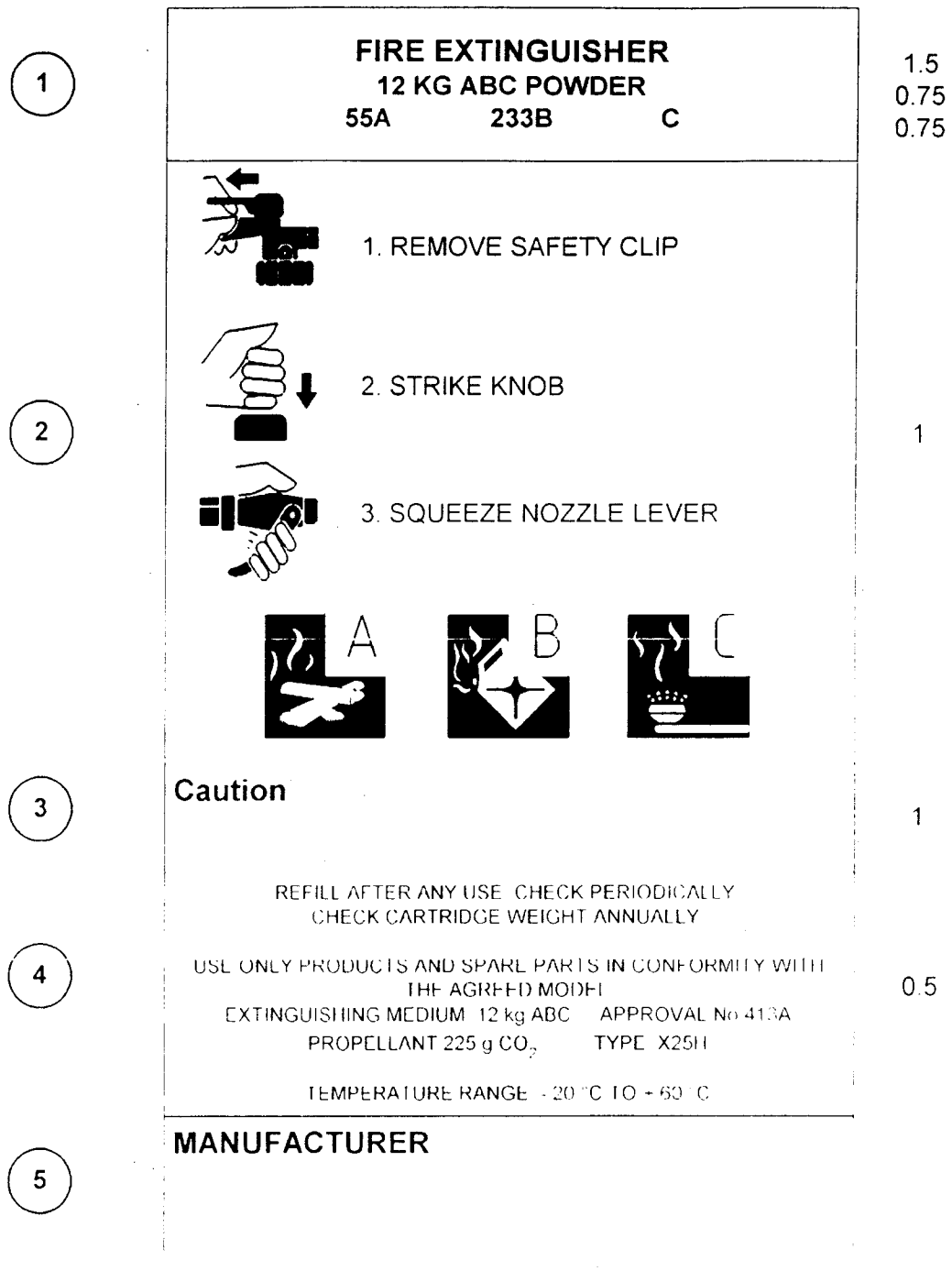

NOTE The circled numbers indicate the parts of the marking and the numbers to the right of each part indicate the height of the lettering as a proportion of *H* (see 16.2).

Figure 2 — Example of marking of an extinguisher

Part 1 shall contain the following information in sequence:

- the words 'FIRE EXTINGUISHER'; or 'EXTINGUISHER' plus medium, or 'FIRE EXTINGUISHER' plus medium;
- the type of extinguishing medium and the nominal charge;
- the fire rating or ratings of the extinguisher ^(A1) (see 6.4, Clause 15, Annex I and Annex L) ^(A1).

Part 2 shall contain the following information:

- the instructions for use, which shall include one or more pictograms each with an explanation;

The text of the instructions for use shall be in the language or languages of the country where the extinguisher is to be used, the different actions to be carried out being shown one after another vertically from top to bottom.

The pictograms shall all be located in the same position with regard to the relevant texts and the direction of the movements to be carried out shall be indicated by arrows.

pictograms representing the type of fires are shown in ^(A1) Figure 3 and Figure L.1. Class A, Class B and Class F pictograms ^(A1) shall only be used where the corresponding fire rating is shown on the marking. Class C pictogram shall only be shown on powder extinguishers where Class C suitability is shown on the marking. These pictograms shall be arranged horizontally on one line under the instructions for use:

^(A1) for extinguishers having additionally passed the requirements of Annex M the words "also suitable for use on polar solvents" immediately under the pictograms representing the types of fire. ^(A1)

The pictograms representing the types of fire shall appear in square boxes of side 20 mm minimum for portable fire extinguishers with a charge of less than or equal to 3 kg or 3 l and 25 mm minimum for portable fire extinguishers with a charge of more than 3 kg or 3 l. A square containing a code letter shall appear at the corner of each pictogram as shown in Figure 3.

Extinguishers claiming class D suitability shall not be marked for suitability of any other fire class.

Part 3 shall contain information relating to any restrictions or dangers of use, in particular in relation to toxicity and electrical risk.

NOTE Attention is drawn to national regulations.

Portable fire extinguishers using water or foam and not tested to, or not meeting the requirements of, clause 9 shall be marked with the following warning: "WARNING Do not use on live electrical equipment".

Portable fire extinguishers using other agents and water based extinguishers meeting the requirements of clause 9 shall be marked to indicate that they are suitable for use on live electrical equipment e.g. "suitable for use on live electrical equipment up to 1 000 V at a distance of 1 m"

NOTE Attention is drawn to national regulations or practice

Part 4 shall contain at least the following:

- an instruction to refill after any operation.
- an instruction to check periodically and to use only products and spare parts in conformity with the agreed model for refilling and maintenance;
- the identification of the extinguishing medium and, in particular, identification and percentage of additives for water based media;

EN 3-7:2004+A1:2007 (E)

- if applicable, the identification of the propellant gas;
- the number(s) or reference(s) relating to the approval of the extinguisher;
- the manufacturer's model designation;
- the operating temperature range;
- a warning against the risk of freezing for water based extinguishers;
- a reference to the European Standard EN 3.

Part 5 shall contain:

- the name and address of the portable fire extinguisher manufacturer and/or supplier.

In addition, the year of manufacture shall be marked somewhere on the portable fire extinguisher.

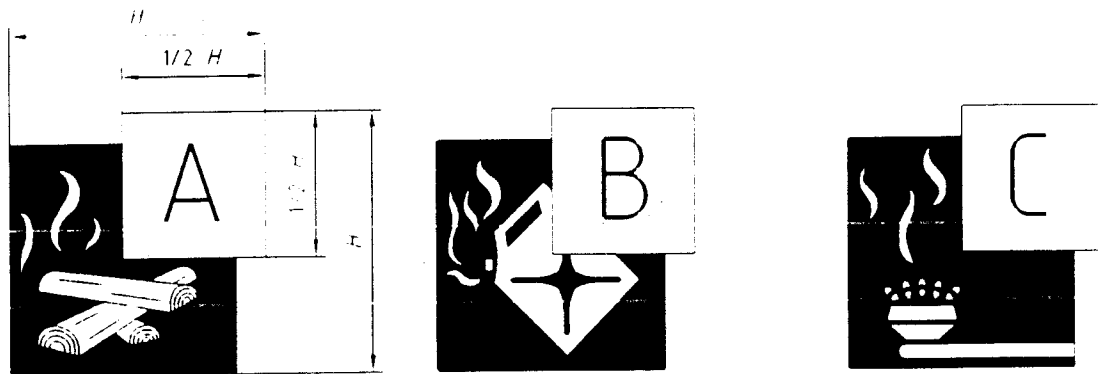

Figure 3 — Pictograms

17 Maintenance

It shall be possible to perform periodic maintenance on each portable fire extinguisher.

NOTE 1 The periodic maintenance interval can be included in the marking given in Part 4 (see 16.2).

NOTE 2 Attention is drawn to national regulations.

Annex A
(normative)

Duration of operation, residual charge tests

NOTE See 7.1, 7.2 and 7.3.

The test shall be carried out on 3 specimens.

Weigh the extinguisher.

Hold the extinguisher in its normal working position (i.e. hand-held) and keep it immobile for the duration of the test.

For those extinguishers supplied with a final control valve and an independent activation system, (see 7.3) pressurise when the final control valve is closed. Open this control valve 6 s after the commencement of pressurisation of the extinguisher.

For extinguishers which are activated by a single operation of the control valve (see 7.3), open the control valve and leave open for the duration of the test.

Measure and record the time between the opening of the control valve and the commencement of discharge. Measure and record the duration of operation.

For gaseous extinguishers: reweigh, calculate and record the residual charge.

For all other extinguishers: reweigh, empty the residual extinguishant, reweigh or measure and record it.

Annex B (normative)

Range of operating temperature

NOTE See 7.4.

B.1 Carry out testing on four extinguishers. Before testing, weigh each extinguisher, then subject two extinguishers to temperature cycle A as given in B.2 and subject the other two extinguishers to temperature cycle B as given in B.3. Storage at the temperatures given in B.2 and B.3 shall be carried out in conditioning chambers. Liquid baths shall not be used. Extinguishers shall remain upright during temperature cycling.

B.2 Temperature cycle A. Store the extinguisher, at each of the following temperatures in succession for (24 ± 1) h:

$(T_{\min} + 2)$ °C, as specified in 7.4.2;

$(+ 20 \pm 5)$ °C;

$(T_{\max} + 2)$ °C.

B.3 Temperature cycle B. Store the extinguisher, at each of the following temperatures in succession for $24 \text{ h} \pm 1 \text{ h}$:

$(T_{\max} + 2)$ °C;

$(+ 20 \pm 5)$ °C;

$(T_{\min} + 2)$ °C, as specified in 7.4.2.

B.4 Operate the extinguisher within 1 min of its removal from the conditioning chamber. The extinguisher shall be operated in accordance with 7.3, except for cartridge type extinguishers where activation is by a single action. In this case the cartridge shall be opened and the control valve closed immediately for a period of 6 s after which the control valve shall be reopened.

B.5 Measure and record the time between the opening of the final control valve and the commencement of discharge. Measure and record the duration of operation.

B.6 For gaseous extinguishers: reweigh, calculate and record the residual charge. For all other extinguishers: reweigh, empty the residual extinguishant, reweigh or measure and record it.

Annex C (normative)

Dielectric test

NOTE See clause 9.

C.1 Apparatus

C.1.1 A metallic plate, the target, (1 · 1) m, hung vertically by insulators and with no object or structure closer than:

- 1 m below the bottom of the plate;
- 1 m either side of the edges of the plate;
- 1 m from either face of the plate;
- 0.5 m above the top of the plate.

C.1.2 A trough or other container, arranged below the target plate to collect any liquid run off from the plate and insulated from earth.

C.1.3 A high voltage transformer, enabling an alternating voltage of 35 kV to be established between the metallic plate and earth.

The impedance of the circuit shall be such that, when the secondary is short circuited and the primary supplied by a voltage equal to 10 % of its normal supply voltage, the secondary current is not less than 0.1 mA.

C.1.4 An insulating support, (for fixed nozzle extinguishers).

C.1.5 An insulating tray, (for extinguishers fitted with a hose).

C.2 Test procedure

The apparatus shall be set up according to the arrangement shown in Figure C.1.

A fixed nozzle type extinguisher shall be fixed onto the insulating support and so arranged that the discharge outlet, situated at 1 m from the metallic plate, the target, is directed towards its centre.

An extinguisher with a hose shall be placed on the insulating tray and so arranged that the discharge outlet is 1 m from the target plate and directed towards its centre.

The current shall be measured by an ammeter connected in turn between the handle of the extinguisher and earth and between the nozzle and earth. If no complete metallic path exists between the extinguishing media and at least one of the above connection points to the measuring device, such a path shall be created for the purpose of the test.

Discharge the extinguisher, ensuring that the discharged medium contacts the target, and measure and record the current.

Dimensions in meters

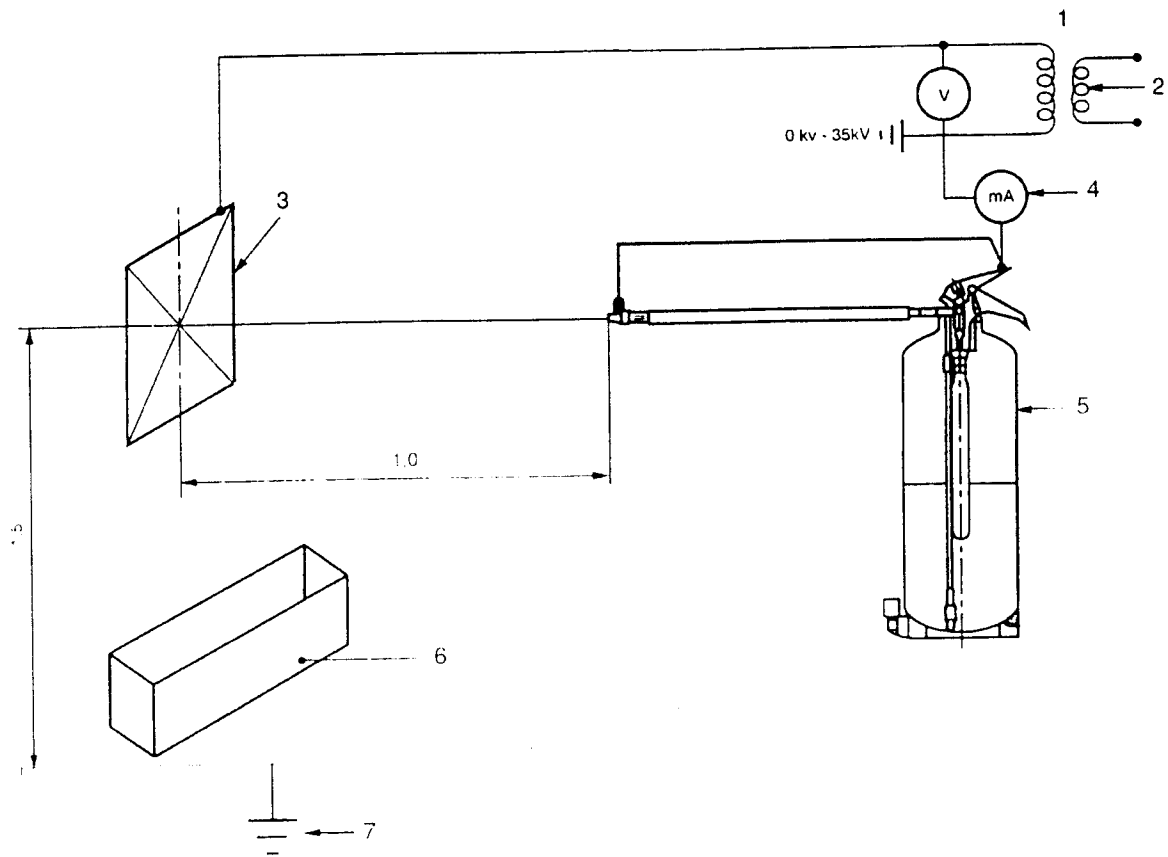

Key

- 1 Test transformer
- 2 Low voltage supply
- 3 Metallic plate
- 4 Ammeter
- 5 Extinguisher under test
- 6 Collecting trough (insulated from earth)
- 7 Earth

Figure C.1 — Schematic arrangement of apparatus for dielectric test

Annex D (normative)

Operation and emission control mechanisms/devices

NOTE See clause 10.

D.1 Measurement of the forces

The forces, which shall be measured with the use of a dynameter, shall be applied statically and perpendicularly at the normal point where force is used to render the extinguisher operable.

D.2 Measurement of energy

☞ The energy of 2 J is obtained by allowing a 4 kg weight (see D.3) to fall from a height of 50 mm. The impact shall be applied in the direction of the operating mode.

NOTE The maximum forces required to operate the extinguisher and release the safety device are specified in Clause 10 ☞

D.3 ☞ Apparatus

The weight (see D.2) shall consist of a cylindrical steel weight with flat surfaces measuring 75 mm in diameter and weighing 4 kg. The weight shall be capable of falling freely. ☞

Annex E
(normative)

Test for performance of the hose

NOTE See 10.5.

Where testing is to be carried out at a temperature other than 20 °C, condition the hose and attached components at the relevant temperature for a period of between 12 h and 24 h:

- test at $(20 \pm 5) \text{ }^\circ\text{C}$ 1 specimen ;
- test at $(T_{\text{max}} \pm 2) \text{ }^\circ\text{C}$ - 2 specimens;
- test at $(T_{\text{min}} \pm 2) \text{ }^\circ\text{C}$ - 2 specimens.

The hose shall be fitted to a means of providing the required pressure and the open end blanked off by suitable means.

Increase the pressure in the hose to the minimum applicable value as specified in 10.5, in a time of not less than 30 s and maintain the pressure for a further 30 s. If the hose does not burst, increase the pressure until the hose does burst and record the pressure at which this occurs.

NOTE Attached components include pistols.

Annex F (normative)

Control valve test

NOTE See 10.6.

F.1 General

This test shall be carried out at (20 ± 10) °C (see 10.6).

The test is carried out on 2 specimens.

F.2 All extinguishers excluding 1 kg and 2 kg powder extinguishers

Operate the extinguisher and allow the medium to discharge for between 5 % and 15 % of the average discharge duration given in 7.1.2.

For extinguishers with a (propellant) gas cartridge, open the control valve in accordance with a) or b) as applicable:

- a) if the extinguisher is fitted with a pressurization device independent of the device which opens the control valve, operate the pressurization device and 3 min later open the control valve to initiate discharge;
- b) if a single action pressurizes the extinguisher and releases the first emission of gas, pressurize the extinguisher initially and 3 min later open the control valve again to permit discharge of the extinguishing medium.

Then close the control valve.

Measure the internal pressure, or in the case of CO₂ the mass, of the extinguisher within 10 s of the control valve having been closed and again after 5 min; the control valve having remained closed for the duration of this period.

F.3 1 kg and 2 kg powder extinguishers

Operate the extinguisher and allow the medium to discharge for between 1 s and 1.5 s.

Then close the control valve.

Measure the internal pressure within 10 s of the control valve having been closed and again after 2 min; the control valve having remained closed for the duration of this period.

Annex G (normative)

Tests on the horn

NOTE See clause 12.

G.1 Static load test

The test is carried out on one specimen.

Place the horn on its side on a rigid surface. Measure the diameter of the wide end of the horn in the vertical plane.

Apply a static load of 25 kg to the wide end of the horn in the vertical plane, using a circular contact surface of 50 mm diameter. Apply the load for 5 min. (48 ± 2) h after removal of the load re-measure the diameter of the wide end of the horn in the vertical plane and examine the horn for damage.

G.2 Temperature test

The test is carried out on two specimens.

Measure the diameter of the wide end of the horn. Bring the horn to a temperature of $(t_{m,1} \pm 2)$ °C and discharge the extinguisher. Re-measure the diameter of the wide end of the horn in the same plane as the first measurement, and examine the horn for damage.

Annex H (normative)

Resistance to corrosion

NOTE See 14.

H.1 External corrosion

Complete sample extinguishers shall be subjected to a salt spray test in accordance with ISO 9227 type NSS for a period of 480 h, and then shall immediately be washed carefully to remove any salt deposits. Two extinguishers shall be tested, either two of the same size or one extinguisher each of two different sizes from the same family which use the same material and method of construction.

H.2 Resistance to water based extinguishing medium

Two extinguishers charged in accordance with the manufacturer's filling instructions, shall be subjected 8 times to the temperature cycle given in Table H.1. Storage at the temperatures specified in Table H.1 shall be carried out in conditioning chambers. Liquid baths shall not be used. The duration of any one complete cycle shall not exceed 120 h.

Table H.1 — Temperature cycle

Stage	Duration h	Temperature °C
1	24 ± 1	$T_{min} + 2$
2	± 24	- 20 ± 5
3	24 ± 1	$T_{max} + 2$
4	± 24	- 20 ± 5

On completion of the eight temperature cycles, the extinguishing medium shall be drained off and examined for colour change, and each extinguisher body shall be cut into two sections in a manner which permits internal examination. Detachment of any protective coating local to the plane of section shall be disregarded.

Annex I (normative)

Fire tests

NOTE See clause 15.

I.1 General

To carry out these tests the operator shall be dressed in clothing suitable for the purpose. The use of a helmet, gloves and approved non-reflective visor shall be permitted. The operator shall not wear an aluminium-faced suit.

Cartridge type extinguishers shall be pressurised prior to the end of the pre-combustion period.

The compaction procedure described in Annex K shall be carried out on each powder extinguisher immediately before submission to the fire test.

I.2 Class A fire test

NOTE See 15.2

I.2.1 Characteristics of test fires

Class A test fires shall consist of a crib of wooden sticks supported on a metal frame 250 mm high, 900 mm wide and of a length equal to that of the test fire (see Figure I.1). The metal frame shall be constructed from angle sections (L x W) (50 x 50) mm as specified in ISO 657-1.

Each test fire is designated by a number (which indicates the fire size) followed by the letter A. The designating number of the test fire represents the following two parameters as shown in Table I.1:

– the length of the test fire in decimetres, i.e., the length of the wooden sticks arranged in the longitudinal direction of the test fire;

– the number of 500 mm wooden sticks for each layer arranged in the transverse direction of the test fire.

NOTE Each test fire is designated by a number in a series in which each term is equal to the sum of the two preceding terms i.e. this series is equivalent to a geometrical progression having a common ratio of about 1.62. The additional fires 27A and 43A represent the product of the preceding term and $\sqrt{1.62}$.

Table I.1 — Characteristics of class A test fires

Designation of test fire	Number of 500 mm wooden sticks in each transverse layer	Length of test fire m
5A	5	0,5
8A	8	0,8
13A	13	1,3
21A	21	2,1
27A	27	2,7
34A	34	3,4
43A	43	4,3
55A	55	5,5

Test fires greater than 27A shall be constructed using fires of smaller sizes (fires, frames and trays) see Table I.2. The ends of the longitudinal sticks shall touch.

Table I.2 — Construction of class A test fires

Fire size	Fire construction
5A	5A
8A	8A
13A	13A
21A	21A
27A	27A
34A	21A + 13A
43A	8A + 27A + 8A
55A	21A + 13A + 21A

To provide adequate support for the wooden sticks for fires larger than 13A, metal cross members shall be added to the frame positioned as for 8A and 13A fires

For example a 21A frame shall have cross members positioned 800 mm from each end.

The wooden sticks shall be of *Pinus silvestris* containing 10 % to 15 % of moisture by mass when determined in accordance with Annex J. They shall be sawn and of square section of side (39 ± 2) mm. The density of the wood shall be 0,40 kg/dm³ to 0,65 kg/dm³.

The wooden sticks shall be stacked in fourteen layers on the metal frame, as shown in Figures I.1 and I.2.

Dimensions in millimetres

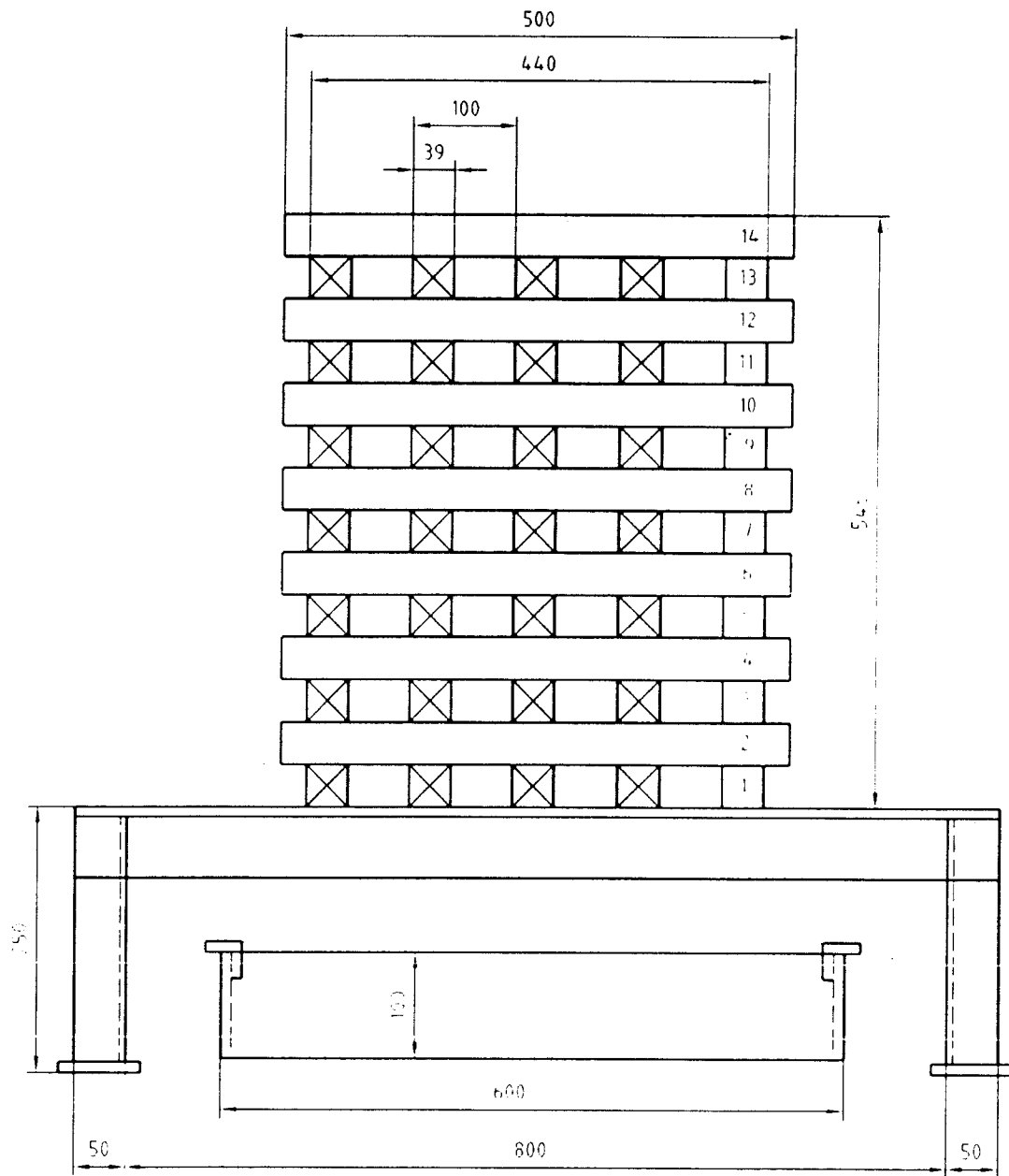

Figure I.1 — Example of class A fire (13 A fire) - Front view (identical for all fires)

Dimensions in millimetres

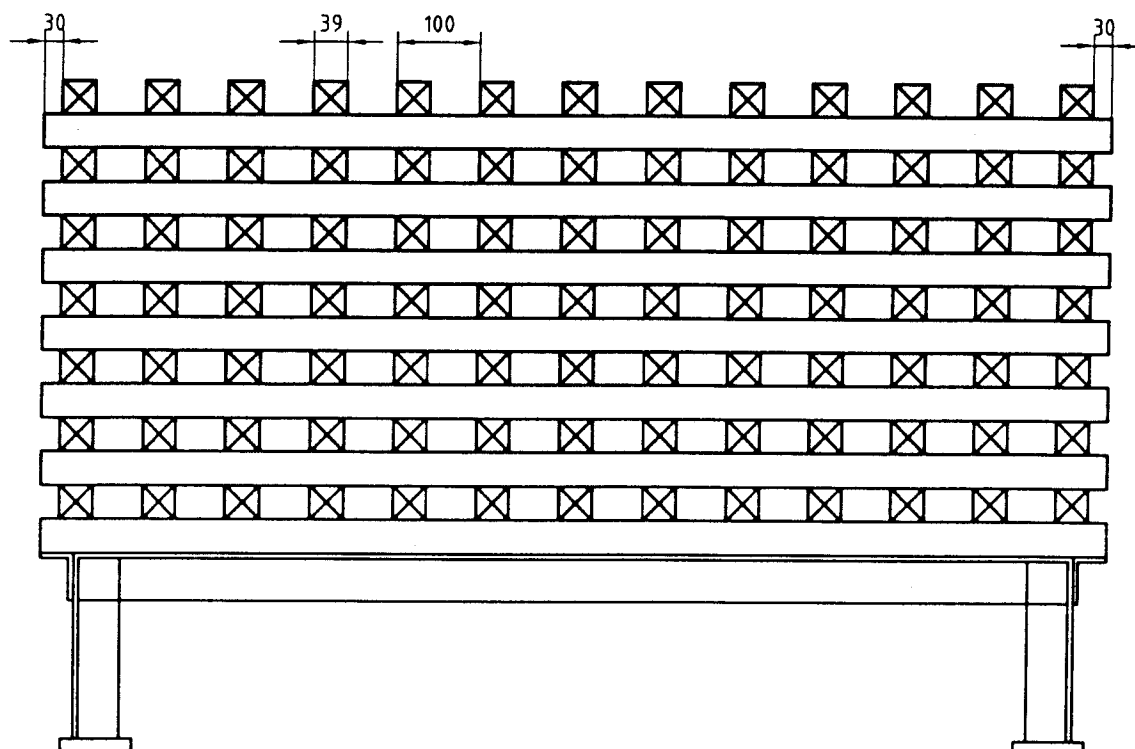

Figure I.2 — Example of class A fire (13 A fire) - Side view (variable according to size of fire)

The sticks in each layer shall be spaced at regular intervals with gaps of 6 cm between the sticks.

The sticks laid transversely (layers 2, 4, 6, 8, 10, 12 and 14) shall have a fixed length of (500 ± 10) mm.

The sticks laid longitudinally (layers 1, 3, 5, 7, 9, 11 and 13) shall have fixed lengths which vary according to the test fire as given in Table I.1, with a tolerance of ± 10 mm.

NOTE When the test fire is constructed using smaller fires, the tolerance applies to the length of the individual sticks

A fire size beyond 55A shall not be used (see Table I.1).

I.2.2 Test conditions

The test fire shall be located indoors in a test chamber and shall be sheltered from draughts. The ambient temperature shall be between 0 °C and 30 °C.

The test chamber shall have the following characteristics:

- minimum height of the house (internal): 8 m;
- area: Around the class A frame there shall be a minimum distance of 3 m to the test house wall. (For example: In the case of a 55A, the room shall have a minimum length of 11,5 m and a minimum breadth of 6,5 m);
- air and surrounding conditions: a) Minimum O_2 concentration throughout the test at a height of between 0,8 m and 1,5 m shall be 19 %. The measuring device shall be attached to the operator;

EN 3-7:2004+A1:2007 (E)

- the maximum air speed before ignition shall be 0,2 m/s measured above the centre of the frame at a height of 0,2 m for horizontal airspeed and at a height of 1 m above the uppermost stick in the crib. The measurement has to be taken before the crib is ignited. During the test and for 3 min after the test no characteristics of ventilation or airflow are allowed to change. The test starts by measurement of the air speed.

A metal lighting tray with a width of 600 mm and a depth of 100 mm shall be used. The length of the tray shall be 100 mm greater than the fire size.

In the case of multiple frames being used to construct the fire, it shall be permissible for the overall length to be increased by 200 mm to 300 mm.

The lighting tray shall be placed symmetrically beneath the crib forming the test fire.

Water shall be added to the tray to a depth of 30 mm. Heptane of a quality identical to that used for the Class B fires (in accordance with I.3.2) shall then be added, the quantity being sufficient to give a burning time of 2 min 30 s.

I.2.3 Test procedure

The heptane shall be ignited.

After the fire has burnt for 2 min, the tray shall be withdrawn from beneath the crib.

The crib shall then be permitted to burn for a further 6 min, making a total pre-test time of 8 min, at which point the test fire can be considered to be established and extinction shall be commenced.

The operator shall then bring the extinguisher into use, and direct the jet onto the test fire while moving round it at his own discretion in order to obtain the best result. The entire contents of the extinguisher may be discharged either continuously or in successive bursts.

The maximum extinguishing time shall not exceed 5 min for fires up to and including 21A and 7 min for fires of a greater size. The operator shall indicate when the extinguisher is fully discharged or when the fire is extinguished within the permitted time.

In both cases the fire shall be observed for 3 min from that point. A new period of 3 min starts in the case of a re-operation within the permitted time.

For the test to be deemed successful, all flames shall be extinguished and there shall be no recurrence of flames during the 3 min observation period.

I.3 Class B fire tests

I.3.1 Characteristics of test fires

Class B test fires shall be made in a range of welded sheet steel circular trays, the dimensions of which are given in Table I.3. The base shall be the same nominal thickness as the walls and the thickness tolerance of the base and wall material shall conform to the relevant national standard. Stiffening bars or sections may be welded to the underside of the base with a minimum distance of 200 mm between substantially parallel stiffeners. All tolerances specified relate to the tray at its time of manufacture.

The trays shall contain water, overlaid with a layer of fuel (see I.3.2) in the following proportion: 1/3 water, 2/3 fuel. The total volume of liquid in the tray shall be as specified in Table I.3, which will give a depth of water of approximately 10 mm, and a depth of fuel approximately 20 mm.

The test fires are designated by a number (which indicates the fire size) followed by the letter B. The number represents the volume of liquid, in litres, contained in the tray.

NOTE Each test fire is designated by a number in a series in which term is equal to the sum of the two preceding terms, i.e. this is equivalent to a geometrical progression having a common ratio of about 1,62. The additional fires 70B, 113B, and 183B represent the product of the preceding term and $\sqrt{1,62}$.

The surface area of the tray in square decimetres is equal to the product of the test fire size and π .

A fire size beyond 233B shall not be used (see Table I.3).

Table I.3 — Construction of class B test fires

Designation of test fire	Volume of liquid (1/3 water + 2/3 fuel) l	Dimensions of tray				
		Internal diameter at rim mm	Depth mm	Thickness of walls mm	Approximate area of fire m ²	Minimum duration of operation s
21B	21	920 ± 10	150 ± 5	2,0	0,66	6
34B	34	1 170 ± 10	150 ± 5	2,0	1,07	6
55B	55	1 480 ± 15	150 ± 5	2,5	1,73	9
70B	70	1 670 ± 15	150 ± 5	2,5	2,20	9
89B	89	1 890 ± 20	200 ± 5	2,5	2,80	9
113B	113	2 130 ± 20	200 ± 5	2,5	3,55	12
144B	144	2 400 ± 25	200 ± 5	2,5	4,52	15
183B	183	2 710 ± 25	200 ± 5	2,5	5,75	15
233B	233	3 000 ± 30	200 ± 5	2,5	7,32	15

The minimum height from the surface of the fuel to the rim of the tray shall be 100 mm for fires up and including 70B and 140 mm for fires of larger sizes.

The height from the ground to the rim of the tray shall not exceed 350 mm. The construction of the tray shall prevent the flow of air under the tray, or sand or earth shall be built around the tray up to but not above the level of the base.

After each test, a minimum of 5 mm of fuel shall remain.

For powder extinguishers, at least one fire in each series shall be successfully extinguished on a fresh water/fuel filling for the rating to be accepted.

For successive tests with CO₂ type extinguishers only, fuel may be added to the existing test fire.

For water based extinguishers, fresh fuel and water shall be used for each test.

I.3.2 Test conditions

The ambient temperature shall be between 0 °C and 30 °C.

Class B Fire tests can be carried out indoors or outdoors.

For indoor fire tests the conditions shall be:

- the height of the test chamber (internal) shall be equal to or greater than 5 times the diameter of the test fire tray;
- the area of the test chamber in square metres (m²) shall be equal to or greater than the test fire designation;
- each side of the test chamber shall be equal to or greater than 4 times the diameter of the test tray with a minimum length of 7.5 m (see Table I.4);
- air and surrounding conditions shall be as defined for Class A fires.

Table I.4 — Minimum dimensions of test chambers

Fire test B	Minimum height (tray x 5) (m)	Minimum side length (tray x 4) and 7,5 m whichever is the greatest (m)	Minimum ground area (m ²)
233	15.2	12.2	233
183	13.5	10.8	183
144	12.0	9.6	144
113	10.6	8.5	113
89	9.4	7.5	89
70	8.3	7.5	70
55	7.4	7.5	56
34	5.8	7.5	56
21	4.6	7.5	56

For outdoor fire tests the wind speed shall not be greater than 3m/s.

The fuel for the class B test fires shall be industrial heptane which shall have the following characteristics:

distillation curve:	84 °C to 105 °C;
difference between initial and final points of distillation:	± 10 °C;
aromatic content (F1):	± 1 %;
density at 15 °C	0,680 to 0,720.

I.3.3 Test procedure

The heptane shall be ignited and then be permitted to burn for 1 min, at which point the test fire can be considered to be established and extinction shall commence within 10 s.

The operator shall then bring the extinguisher into use, and direct the jet onto the test fire while moving round at his own discretion in order to obtain the best result. The entire contents of the extinguisher may be discharged either continuously or in successive bursts.

The operator shall indicate when the extinguisher is fully discharged or when the fire is extinguished.

For the test to be deemed successful, all flames shall be extinguished.

Annex J
(normative)

Measurement of moisture content of wood

NOTE See I.2.1.

The moisture content of wood shall be determined in accordance with ISO 4470. The measurements shall be made on at least 5 samples each (500 ± 10) mm long.

Annex K (normative)

Compaction procedure

NOTE See clause 5.

K.1 Apparatus

The compaction machine shall be designed to accept only one extinguisher at a time, which shall be raised by a rod and guided by castors. The plate supporting the extinguisher shall be steel, (300 ± 5) mm square and (60 ± 1) mm thick.

The compaction machine shall conform to the following:

- the rod shall be adjustable to adjust to the extinguisher base;
- the rod shall be able to move freely;
- the extinguisher shall be guided without constraint in the guide castors;
- the impact shall take place on the steel plate and not on the rod;
- the cam to be used is shown in Figure K.1.

K.2 Procedure

The extinguisher, in the condition in which it is put into service, i.e. filled and charged according to the manufacturer's instructions with the extinguishing agent specified by the manufacturer for use in that extinguisher, and conditioned (20 ± 5) °C shall be subjected to the compaction procedure.

The extinguisher shall be held in the vertical position in the compaction machine and dropped vertically 500 times, from a height of 15 mm, at a frequency of 1 Hz, onto a rigid horizontal steel plate.

Annex L (normative)

A1) Specific requirements for Class F fire extinguisher

L.1 General

Portable fire extinguishers for use on cooking oil fires shall have a class F test fire rating.

Powder and carbon dioxide fire extinguishers should not be used on Class F fires as their use on this type of fire is considered hazardous. For this reason powder and carbon dioxide fire extinguishers shall neither be tested according to this annex or marked with the "F" pictogram.

NOTE Extinguishers may also have class A and/or B fire ratings

L.2 Class F test fire ratings

L.2.1 Class F fire rating

Extinguishers shall have a class F fire rating in accordance with Table L.1 when tested in accordance with L.5.

Table L.1 — Fire rating minimum duration of operation and nominal charges for class F extinguishers

Rating	Volume of cooking oil in test fire (l)	Test apparatus mm	Nominal permitted charges (l)	Minimum duration of operations s
5F	5 (+1 -0)	See Figure L.2	2, 3	6
25F	25 (+1 -0)	See Figure L.3 X = 578 Y = 289	2, 3, 6	9
40F	40 (+1 -0)	See Figure L.3 X = 600 Y = 450	2, 3, 6, 9	12
75F	75 (+1 -0)	See Figure L.3 X = 1 000 Y = 500	2, 3, 6, 9	15

L.3 Dielectric test

All extinguishers usable on class F purposes shall conform to the requirements of the dielectric test in Clause 9.

L.4 Pictogram

See Figure L.1.

L.5 Class F fire test

L.5.1 General

To carry out these tests, the operator shall be dressed in clothing suitable for the purpose. The use of a helmet, gloves and approved non reflective visor shall be permitted. The operator shall not wear an aluminium-faced suit.

The ambient temperature of the test facility prior to ignition shall be between 0 °C and 30 °C.

Cartridge type extinguishers shall be pressurized prior to the end of the pre-combustion period.

L.5.2 Class F test fire

L.5.2.1 General

Method of fire fighting

The operator shall discharge the entire contents without interruption from a minimum distance as recommended by the manufacturer on the label after the pre-burn time.

The attack shall take place from only one direction or side of the fire tray.

L.5.2.2 Apparatus

L.5.2.2.1 General

The cooking oil test fires shall be conducted using a steel tray to simulate a deep fat fryer.

L.5.2.2.2 5F Fire tray

5F fire test tray, constructed of steel sheet, $(2,0 \pm 0,25)$ mm thick and (170 ± 10) mm deep and mounted on a support structure (see Figure L.2).

L.5.2.2.3 25F, 40F and 75F fire test tray

25F, 40F and 75F fire test tray, constructed of steel sheet $(2,0 \pm 0,25)$ mm thick and (250 ± 10) mm deep (see Figure L.3 and Table L.2). The tray shall have liquid-tight joints, and the reinforcing angle shall be continuous around the perimeter of the tray to produce a turned-out edge level with the top of the tray. The width of the top edge shall be 45 mm. The tray shall be mounted on a supporting structure which raises the top of the tray to a height of $(1\ 000 \pm 12)$ mm above the floor.

L.5.2.2.4 Thermocouple

In order to monitor the oil temperature, a thermocouple shall be located (25 ± 5) mm below the oil surface (before heating), but not closer than 75 mm to the test fire tray's walls.

L.5.3 Combustible oil

Pure edible vegetable oil, with an auto-ignition temperature range of between 330 °C and 380 °C.

L.5.4 Procedure

The test chamber shall have the following characteristics:

- minimum height of the house (internal): 8 m;
- area: Around the tray there shall be a minimum distance of 3 m to the test house wall. (For example: In the case of a 75F, the room shall have a minimum length of 4,5 m and a minimum breadth of 3,5 m).

Heat the oil in the fire test tray using a suitable heating arrangement until non-piloted auto-ignition occurs.

Auto-ignition shall occur in a maximum time of 3,5 h from the start of heating of the apparatus.

When auto-ignition occurs

Turn off the heat source and allow to burn freely for (120 ± 10) s before commencement of fire fighting.

After each test, clean the apparatus thoroughly and renew with fresh oil prior to subsequent fire testing.

NOTE Care should be taken to avoid the fuel vapours being ignited by the heat source before auto ignition occurs.

L.5.5 Fire test requirements/measurements

Portable fire extinguishers shall conform to the following requirements.

- a) Burning material shall not be ejected.
- b) The fire shall be extinguished and there shall be no re-ignition of the test fire, or any overflow of fuel during a 20 min period following the complete discharge of the extinguisher.
- c) Oil shall remain in the tray at the end of the test to prove that extinguishment has occurred by application of the extinguishant and not by oil starvation.
- d) The oil temperature shall be monitored at auto-ignition.
- e) Application of the media shall not cause enlargement of the flames.

NOTE Flames over 2 m in height constitute enlargement. Short term flame peaks (< 2 s in duration) above 2 m are acceptable.

Video recording of the fire tests shall be carried to establish compliance with this requirement.



Figure L.1 — Class F pictogram

Dimensions in millimetres

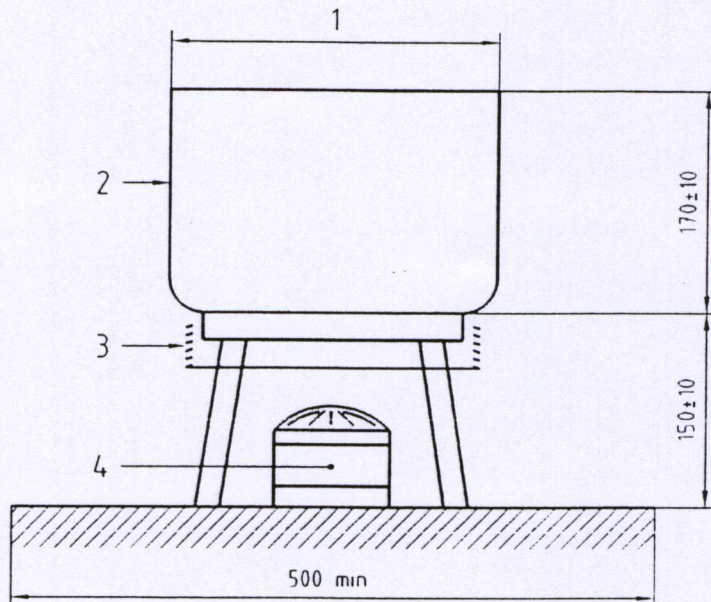

Key

- 1 pan diameter
- 2 nominal wall thickness
- 3 skirt to suit burner type
- 4 burner

Figure L.2 — Fire test apparatus – 5F

Dimensions in millimetres

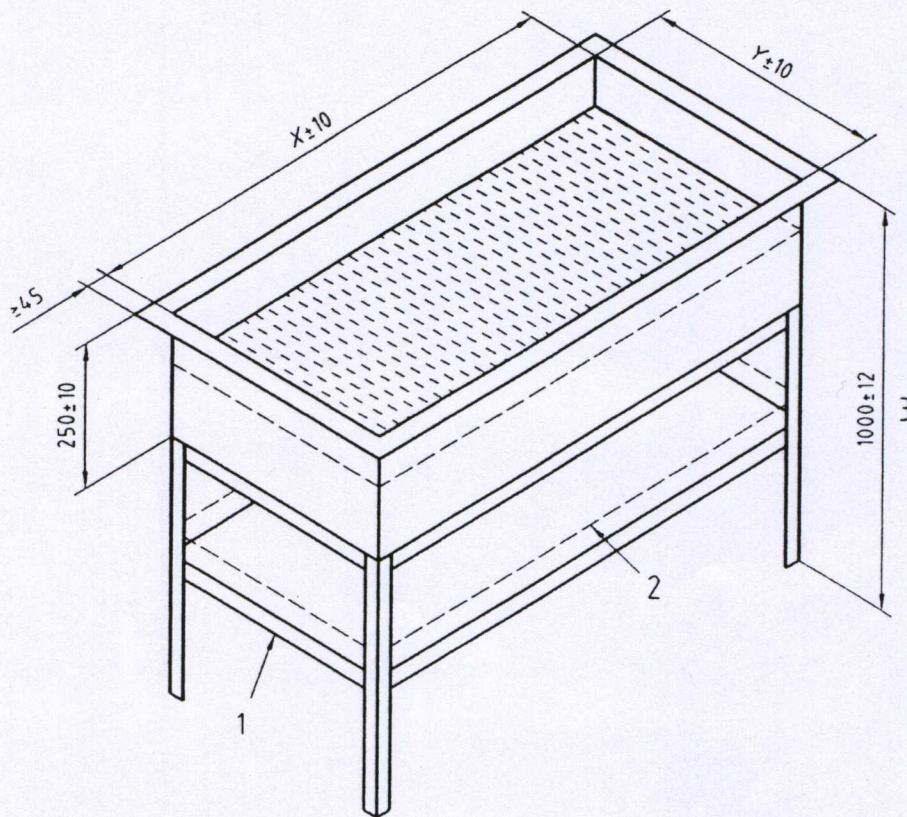

Key

- 1 tray to support gas burners (alternatively electric heating may be used)
- 2 skirts to contain flames for gas heating (to prevent pilot ignition)
- 3 distance to floor level
- X internal length (see Table L.1)
- Y internal width (see Table L.1)

Figure L.3 — Fire test apparatus – 25F, 40F and 75F (A₁)

Annex M (normative)

A1 Polar solvents

M.1 General

This annex is to be used to provide the assurance that extinguishers have the capability of extinguishing fires involving polar solvents.

Powder and CO₂ extinguishers are considered suitable for this purpose and need not be subjected to the requirements of this annex.

M.2 Characteristics of test fires (polar solvents)

Polar solvent test fire shall be made in a welded sheet steel circular tray, the dimensions of which are as follows

Internal diameter	mm	1 170 ± 10
Depth	mm	150 ± 5
Thickness of walls	mm	2,5
Approximate area of fire	m ²	1,07

(NOTE The above dimensions are of a 34B Fire Tray.)

The height from the ground to the rim of the tray shall not exceed 350 mm. The construction of the tray shall prevent the flow of air under the tray or sand or earth shall be built around the tray up to but not above the level of the base.

Fresh fuel shall be used for each test and the tray shall be cleaned and dried between tests.

M.3 Test conditions

The ambient temperature shall be between 10 °C and 20 °C.

The fuel temperature shall be (17,5 ± 2,5) °C.

The test fire shall be carried out indoors.

For indoor fire tests the conditions shall be:

- the height of the test chamber (internal) shall be equal to or greater than 5,8 m;
- the area of the test chamber in square metres (m²) shall be equal to or greater than 56 m²;
- each side of the test chamber shall be equal to or greater than 7,5 m.

Fuel shall be acetone minimum 99 % pure.

To carry out these tests the operator shall be dressed in clothing suitable for the purpose. The use of a helmet, gloves and approved non-reflective visor shall be permitted. The operator shall not wear an aluminium-faced suit.

Cartridge type extinguishers shall be pressurised prior to the end of the pre-burn period.

M.4 Test procedure

The forty five litres (45 l) of fuel, with no water in the tray, shall be ignited and then permitted to burn for 2 min, at which point the test fire can be considered to be established and extinction shall commence within 10 s.

The operator shall then bring the extinguisher into use and direct the discharge onto the test fire while moving round at his own discretion in order to obtain the best result. The entire contents of the extinguisher may be discharged either continuously or in successive bursts.

The operator shall indicate when the extinguisher is fully discharged or when the fire is extinguished.

M.5 Requirements

- a) A portable fire extinguisher shall be deemed to satisfy these requirements when two test fires of a series of three are extinguished. A test series is complete after three fires or when the first two fires have both been extinguished or have both not been extinguished. Each test series shall be completed before the next is commenced. There is no restriction on the number of series that may be carried out on the same type of portable fire extinguisher without modifications, but a series shall consist of consecutive fires and results shall not be ignored.
- b) The fire shall be extinguished within 3 min of the end of the pre-burn time.
- c) For the test to be deemed successful, all flames shall be extinguished. 

Bibliography

EN 615, *Fire protection — Fire extinguishing media — Specifications for powders (other than Class D powders)*

EN 25923, *Fire protection — Fire extinguishing media — Carbon Dioxide (ISO 5923)*

European Council Regulation 2037/2000